

Simmerring Radiamatic® R 36

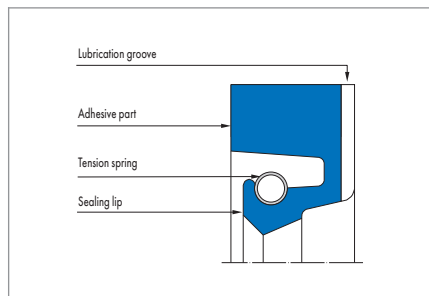

Product description

Simmerring with a fabric reinforced static part that is securely joined to the elastomer sealing lip. The sealing lip is also pre-loaded with a garter spring.

Product advantages

Sealing ring is used, in case of adequate lubrication by the medium to be sealed, preferably where shafts pass through walls in mills and large gearboxes in heavy machinery manufacture.

- Particularly robust static part
- Lasting radial contact pressure
- Highly wear-resistant
- With design measures, e.g., metal support for the sealing lip, higher pressures are possible
- Overpressure requires the usage of endless seals
- Back-up ring drawings and installation instructions for open seals are available

Application

- Ship building
- Steel hydraulics engineering
- Rolling mills
- Wind power plants

Material

| Sealing lip | Static part | Tension spring |
|--------------|------------------------------------|----------------|
| 80 NBR B241 | Impregnated cotton fabric B4 B248 | ST 1.4571 |
| 80 FKM K670 | Impregnated aramide fabric C2 K670 | ST 1.4571 |
| 75 HNBR U467 | Impregnated aramide fabric C2 U464 | ST 1.4571 |

Operating conditions

| | |
|------------|----------|
| Pressure p | 0,05 MPa |
|------------|----------|

| | |
|-----------------|---------|
| Running speed v | 25* m/s |
|-----------------|---------|

* Running speed at 80 NBR B241: 20 m/s.

| Medium/ Temperature | 75 HNBR U467 | 80 FKM K670 | 80 NBR B241 |
|----------------------|--------------------|--------------------|--------------------|
| Mineral oils | -20 °C ... +140 °C | -10 °C ... +180 °C | -30 °C ... +100 °C |
| Water | +5 °C ... +100 °C | +5 °C ... +80 °C | +5 °C ... +100 °C |
| Mineral greases | -20 °C ... +140 °C | -10 °C ... +180 °C | -30 °C ... +100 °C |
| Rolling oil emulsion | on enquiry | on enquiry | on enquiry |

Other media on enquiry. Application parameters are recommended values, do not utilise all parameters simultaneously.

Design notes

Please observe our general design notes in → Technical Manual.

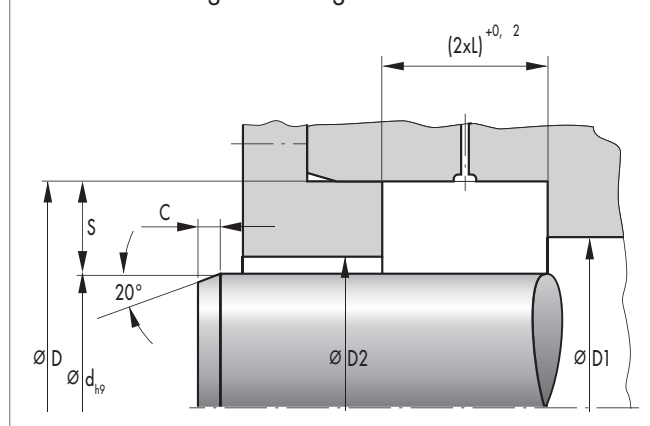

Surface quality

| Peak-to-valley heights | R _a | R _{max} |
|------------------------|----------------|------------------|
| Sliding surface | ≤0,6 µm | ≤2,5 µm |
| Housing | ≤4,0 µm | ≤15,0 µm |

The contact area is machined by plunge grinding, i.e. without feed. The surface hardness must be approx. 60 HRC (depth of hardening min. 0,5 mm). With increasing circumferential speed the contact area should be manufactured with increasing peak-to-valley heights R_a. The surface should not be too smooth so that an adequate film of lubricant can form. Recommended value: R_{a min} = 0,1 µm. Percentage contact area M_r >50% to max. 90% at cutting depth c = Rz/2 and reference line C ref = 0%. Abrasive surfaces, ridges, scratches and blow-holes are to be avoided

Tolerances

| Nominal Ø D | D | d |
|-------------|-------------|----|
| ≤500 mm | H8 | h9 |
| >500 mm | +0,0004 x D | h9 |

Overall eccentricity

The permissible overall eccentricity (static and dynamic eccentricity) between shaft and housing is dependent on the seal profile and circumferential speed. If necessary, we will provide recommended values.

Simmerring Radiamatic® R 36

Fitting & installation

For Simmerring Radiamatic R 36 an axially accessible housing is necessary, as the rings must have low inclination. The Radiamatic R 36 rings are supplied with oversize seal width. For reliable function the Radiamatic R rings must be axially compressed to the dimension "L". An open housing with cover plate and tightening screws is necessary. Specific deformation forces are necessary for the compression. The cover plate and the tightening screws are to be designed appropriately. Please request recommended values.

Lead-in chamfers

See dimension "C" in the article list.

Housing recommendations for new designs

| d | S (Profile) | L |
|---------|-------------|-------|
| >100 mm | 20 mm | 16 mm |
| >250 mm | 22 mm | 20 mm |
| <450 mm | 25 mm | 22 mm |
| >750 mm | 32 mm | 25 mm |